

Ersatzteilliste

HT 214



Member of the
Ziegler Group

ZIEGLER |



Verwenden Sie nur ORIGINAL-ZIEGLER-ERSATZTEILE. Der Einbau von Fremdfabrikaten kann zu schweren Schäden und zum Verlust unserer Gewährleistung führen. Nachgebaute Teile, speziell Zinken, entsprechen selten den Anforderungen, und die Materialqualität kann man nicht optisch prüfen. Darum immer nur ORIGINAL-ZIEGLER-ERSATZTEILE verwenden!

Fit only ORIGINAL-ZIEGLER PARTS. The use of other makes may lead to serious damage and the loss of our warranty. Imitation products, in particular tines, hardly ever meet the requirements and the quality of the material cannot be checked optically. The refore only use ORIGINAL-ZIEGLER parts at all times!

Utilisez exclusivement des pièces détachées d'origine ZIEGLER!
L'utilisation de pièces de contre-facon peut entraîner de sérieuses détériorations, et surtout vous faire perdre votre garantie.
Il est rare que les pièces de contre-facon -principalement les dents- répondent à vos besoins, et de plus, leur qualité ne peut pas vérifiée visuellement.
ALORS, UN CONSEIL: N'UTILISEZ QUE LES PIECES D'ORIGINE ZIEGLER!

Gebruikt U alleen ORIGINELE ZIEGLER ONDERDELEN. Door montage von imitatie-delen kann er zware schade aan de machine ontstaan en kann de garantie vervallen. Immitatie-delen, in het bijzonder de tanden, voldoen slechts zelden aan door ons gestelde eisen. Materiaalkwaliteit kunt U optisch niet beoordelen. Een reden te meer om ORIGINELE ZIEGLER ONDERDELEN te monteren.

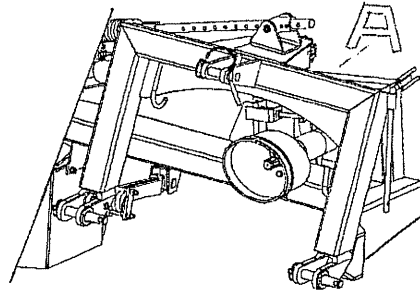

Jede Maschine ist mit einem Typenschild versehen (siehe Abb. 1, Pos. A). Auf diesem Schild sind Maschinen-Typ (Abb. 3. Pos. C), Maschinen-Nummer (Abb. 3, Pos. D) und Baujahr (Abb. 2, Pos. E) angegeben. Diese Angaben müssen für jeden Kundendienstfall oder für die Nachbestellung von Ersatzteilen mitgeteilt werden. Teile deren Pos.- Nr. in einer Klammer stehen unbedingt mit Kleber einsetzen (Bsp.: obige Abbildung, Pos. E).

← = bis Masch.-Nr. = 111380 → ab Masch.-Nr. 111380

Each machine is provided with one serial plate (see Fig. 1, pos. A) which contains details of the model (Fig. 3, pos. C), serial Number (Fig. 3, pos. D) and year of manufacture (Fig. 3, pos. E). This information must be communicated for customer service or when reordering spare parts. Parts with position numbers in brackets must absolutely be fitted in with glue (see Fig. 2, pos. E).

← = below mach.-no. 111380 → =above mach.-no. 111380

Chaque machine est pourvue en une plaque d'identification (voir fig. 1, pos. A). Sur cette plaque d'identification figure, entre autres, le modèle de la machine (fig. 3, pos. C) ainsi que le numéro de la machine (fig. 3, pos. D) et l'année de production (fig. 3, pos. E). Ces références doivent être communiquées à tout service après-vente ou à l'occasion de chaque commande de pièces détachées. Les pièces dont les numéros sont indiqués en parenthèses doivent indispensablement être mises en place avec de la colle (voir Fig. 2, pos E).

← = jusqu'à n°. 111380 → =à partir de n°. 111380

Elke machine is van een type-plaatje voorzien (afb. 1, pos. A). Op dit plaatje staat het type (afb. 3, pos. C), het serienummer (afb. 3, pos. D) en het bouwjaar (afb. 3, pos. E) aangegeven. Voor elke aanspraak op service of bij het bestellen van onderdelen zijn deze gegevens nodig. De delen waarvan de positie-nummers tussen haaktes staan, monteren met een vorgvloeistof (bijvoorbeeld afbeelding Pos. E).

← = tot Mach.-Nr. 111380 → = vanaf Mach.-Nr. 111380



Abb. 3:



HT 214

Pos.	Benennung		Seite
1	Tragbock		3
2	Schwingarm		4
3	Schwenklager		5
4	Ausrastelement		6
5	Zuggestänge mit Hydraulik		7
6	Gestänge		8
7	Federentlastung		9
8	Antrieb 540 U/min		10
9	Getriebebalken		11
10	Anbauteile		12
11	Winkelgetriebe		13
12	Trommelantrieb		14
13	Mähscheibe		15
14	Gelenkwelle		16
15	Schutz		17
16	Aufkleberliste		18

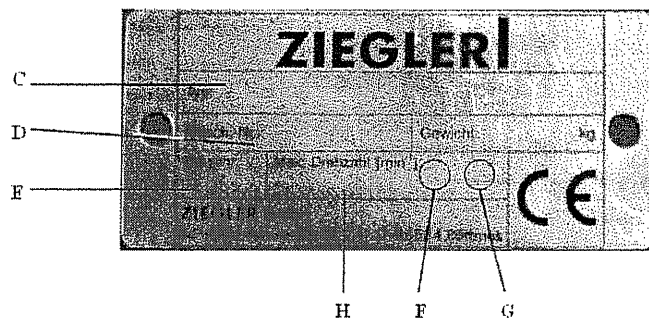
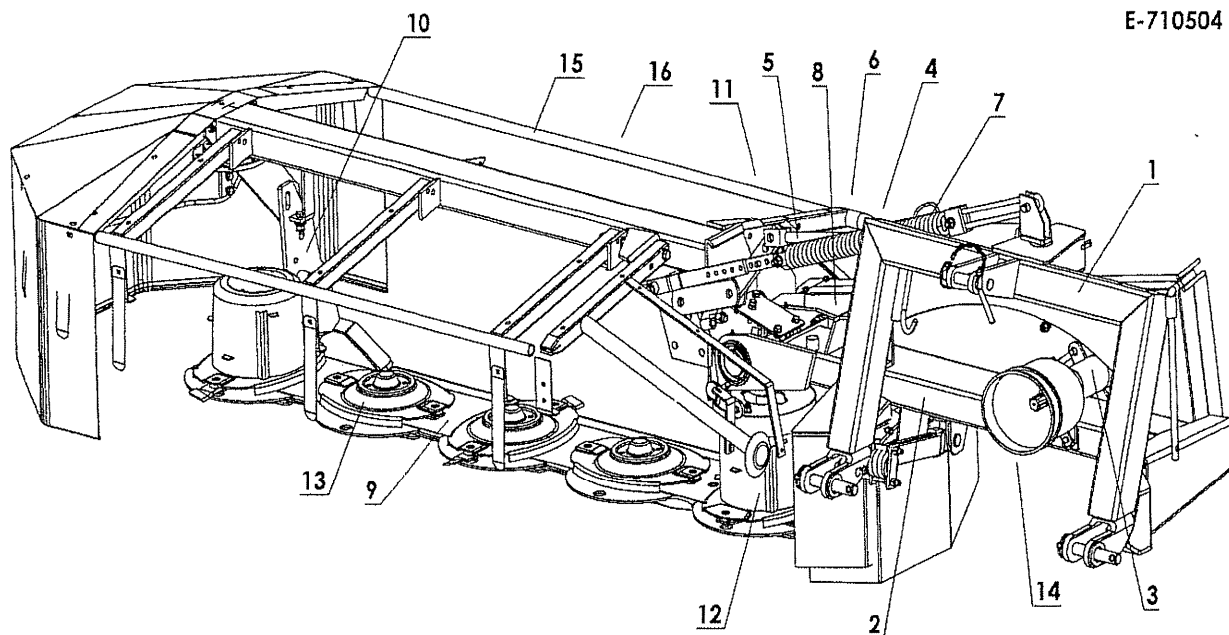
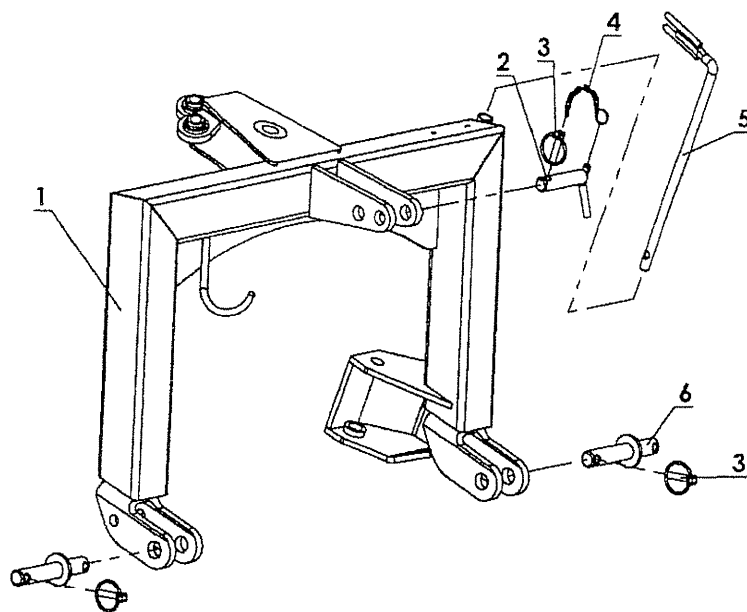

Pos	Id-Nr.	Stk.	Beschreibung	Description	Désignation	Benaming
-----	--------	------	--------------	-------------	-------------	----------

2271

Tragbock

1	051686	1	Tragbock	Headstock	Tete d'attelage	Draagbok
2	052083	1	Oberlenkerbolzen	Top link pin	Broche de 3e point	Topstangpen
3	570246	3	Klappstecker	Linch pin	Attache rapide	Borgpen
4	520642	1	Kette	Chain	Chainette	Ketting
5	017176	1	Knipphebel	Lever	Levier pour couteaux	Sieutel
6	051688	2	Bolzen	Pin	Axe	Pen

DIN 11023

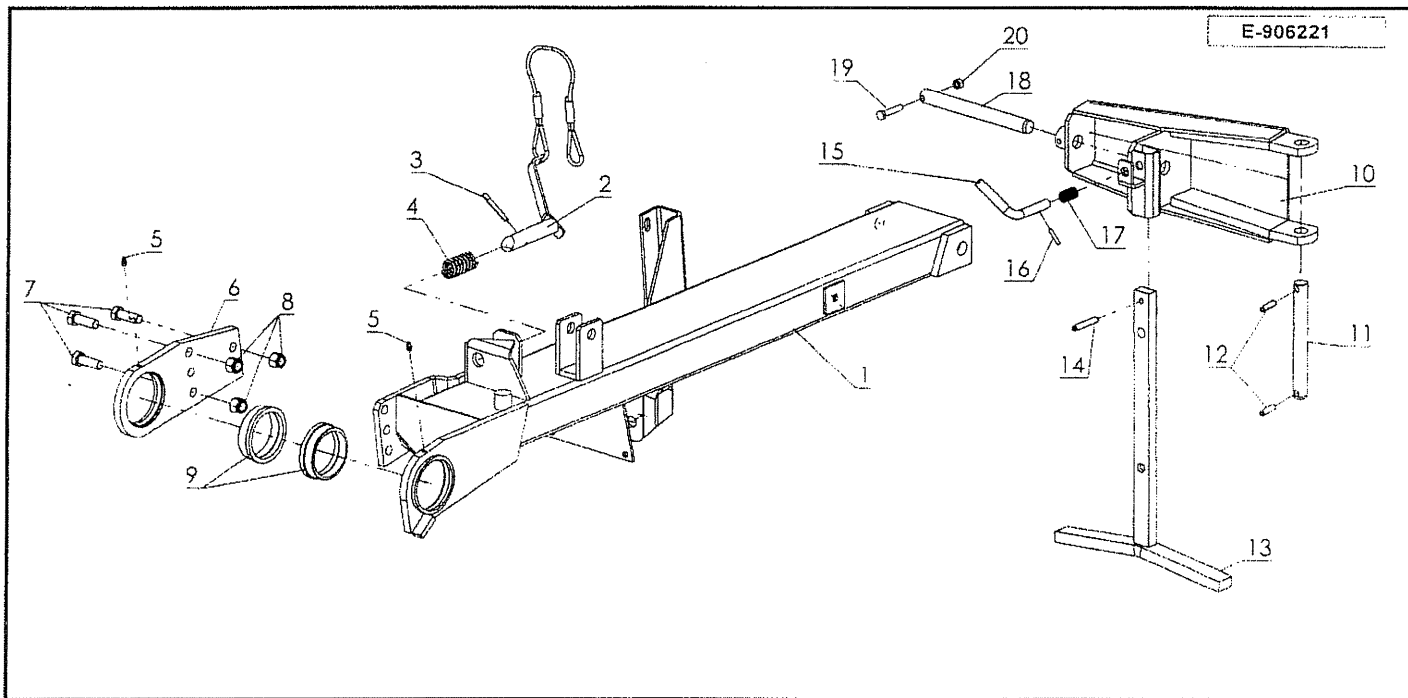

Pos	Id-Nr.	Stk.	Beschreibung	Description	Désignation	Benaming	
1	051880	1	Ausieger	Bracket	Bras	Steun	
2	051836	1	Bolzen	Pin	Axe	Pen	
3	530177	1	Spannhülse	Tension pin	Goupille élastique	Spannhuls	8x65 vz
4	560386	1	Druckfeder	Compression spring	Ressort	Drukveer	D3,5 DE34 LO 68 vz
5	570265	2	Schmiernippel	Grease nipple	Graisneur	Smeernippel	H1S 8x1
6	051831	1	Schwenkarm	Pivot arm	Bras pivotable	Zwenkarm	
7	501262	3	Sechskantschraube	Hex. bolt	Vis	Bout, zeskant	M16x1,5x45DIN961 12.9 vz
8	510538	3	Sechskantmutter	Hex. nut	Ecrou	Moer, zeskant	M16x1,5 DIN985 8 vz
9	051830	1	Buchse	Bushing	Bague	Bus	
10	051832	1	Führung	Guide	Guidage	Geleiding	
11	051838	1	Bolzen	Pin	Axe	Pen	
12	530207	2	Spannhülse	Tension pin	Goupille élastique	Spanhuls	10x40 DIN 1481 vz
13	051837	1	Stütze	Support	Support	Steun	
14	530115	1	Spannhülse	Tension pin	Goupille élastique	Spanhuls	10x60 DIN 1481vz
15	051834	1	Bolzen	Pin	Axe	Pen	
16	530072	1	Spannhülse	Tension pin	Goupille élastique	Spanhuls	6x30 DIN 1481 vz
17	560384	1	Druckfeder	Compression spring	Ressort	Drukveer	
18	051833	1	Bolzen	Pin	Axe	Pen	
19	500900	1	Sechskantschraube	Hex. bolt	Vis	Bout, zeskant	M 10x50 DIN 933 8.8 vz
20	510450	1	Sechskantmutter	Hex. nut	Ecrou	Moer, zeskant	M 10 DIN 980 8 vz

Schwingarm

2272

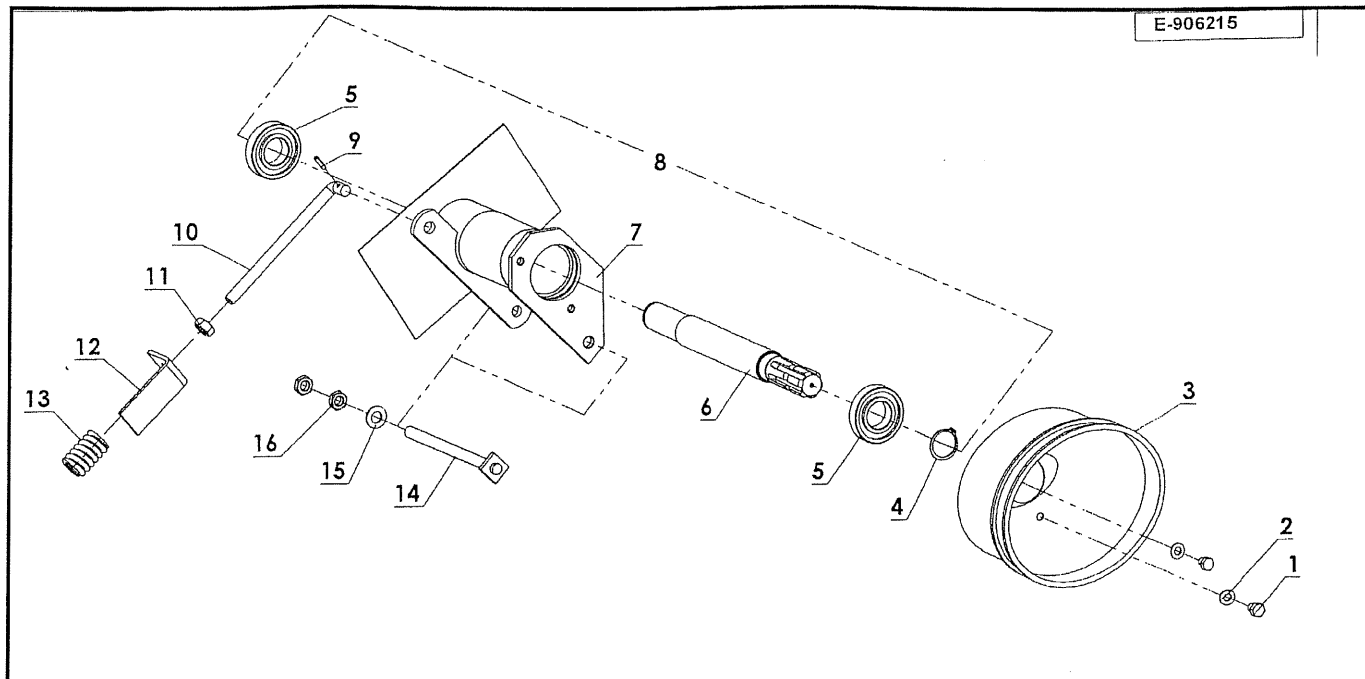

Pos Id-Nr. Stk. Beschreibung Description Désignation Benaming

2273

Schwenklager

1	500758	2	Sechskantschraube	Hex. bolt	Vis	Bout, zeskant	M 10x12 VZ DIN933
2	520049	2	Scheibe	Washer	Rondelle	Schijf	10,5/21x2 DIN 125 vz
3	610727	1	Schutztopf	Protective lid	Protecteur	Beschermkap	82.04
4	531524	1	Sicherungsring	Securing ring	Jonc d'arret	Borgring	A35x1,5 DIN472
5	540164	2	Rillenkugellager	Grooved ball bearing	Roulement	Kogellager	6207 2RS
6	051841	1	Antriebswelle	Drive shaft	Arbre d'entraînement	Aadrijftandwielen	
7	051839	1	Lagerrohr	Bearing tube	Support tubulaire	Lagerbuis	
8	051840	1	Schwenklager	Swivel bearing	Pailier	Lagerhouder	
9	530051	1	Spannhülse	Tension pin	Goupille élastique	Spanhuls	5x20 DIN 1481 vz
10	051843	1	Gewindestange	Rod, threaded	Tige filetée	Draadeind	
11	510238	1	Sechskantmutter	Hex. nut	Ecrou	Moer, zeskant	M14 DIN934 8 vz
12	051844	1	Winkel	Bracket	Corniere	Hoek	
13	021341	1	Druckfeder	Compression spring	Ressort	Drukveer	
14	051842	1	Achse	Axle	Arbre creux	As	
15	520103	1	Scheibe	Washer	Rondelle	Schijf	15/28x2,5 DIN125 vz
16	510308	2	Sechskantmutter	Hex. nut	Ecrou	Moer, zeskant	M 14 DIN 936 vz

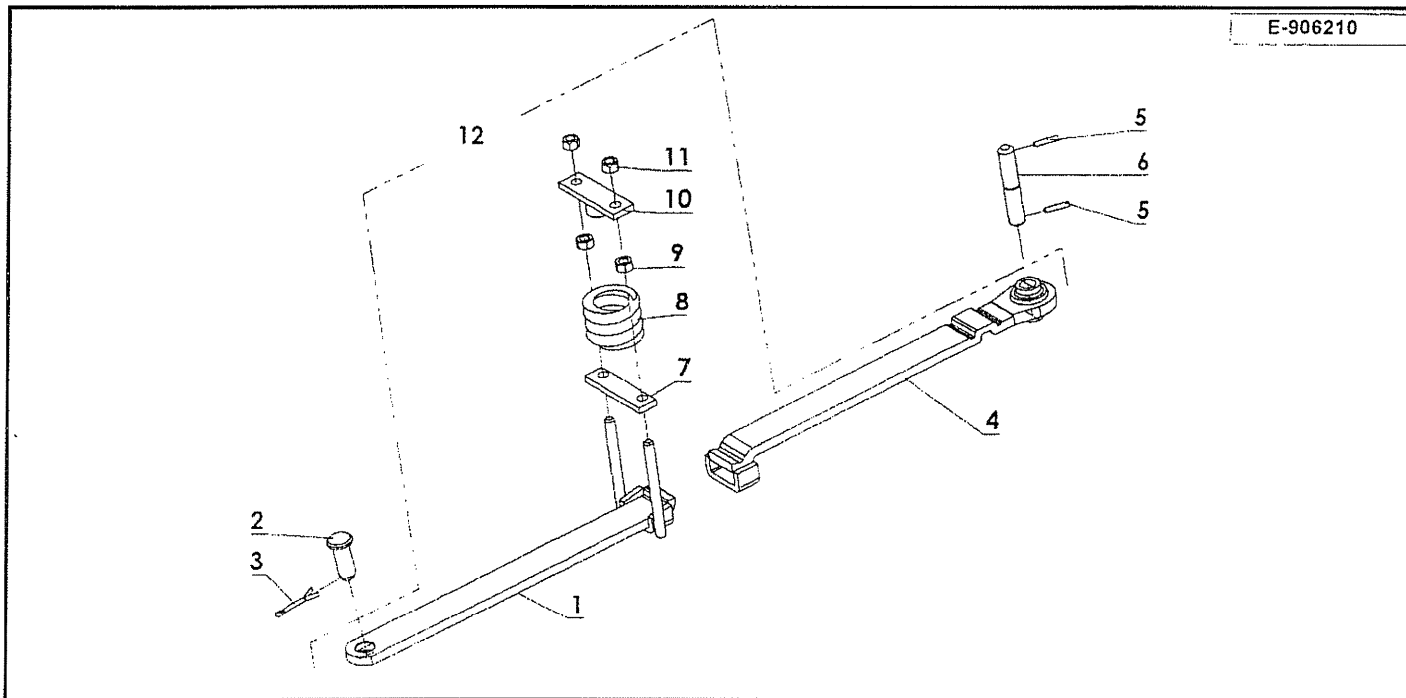

Pos	Id-Nr.	Stk.	Beschreibung	Description	Désignation	Benaming
-----	--------	------	--------------	-------------	-------------	----------

2274

Ausrastelement

1	051689	1	Schiene	Rail	Rail	Geleider	
2	051695	1	Bolzen	Pin	Axe	Pen	
3	530340	2	Splint	Split pin	Goupille fendue	Splitpen	5x35 DIN94
4	051691	1	Führung	Guide	Guidage	Geleiding	
5	530072	2	Spannhülse	Tension pin	Goupille élastique	Spanhuls	6x30 DIN 1481 vz
6	051694	1	Bolzen	Pin	Axe	Pen	
7	051692	1	Lasche	Tongue	Eclisse	Strip	
8	560245	1	Druckfeder	Compression spring	Ressort	Drukveer	D12,5 DE 54,5 LO 69
9	510229	2	Sechskantmutter	Hex. nut	Ecrou	Moer, zeskant	M12 DIN934 8 vz
10	051693	1	Lasche	Tongue	Eclisse	Strip	
11	510451	2	Sechskantmutter	Hex. nut	Ecrou	Moer, zeskant	M 12 DIN 980 8 vz
12	051690	1	Sicherheitsausrüstung	safety release	dispositif de sécurité	Uitzwenkbeveiliging	

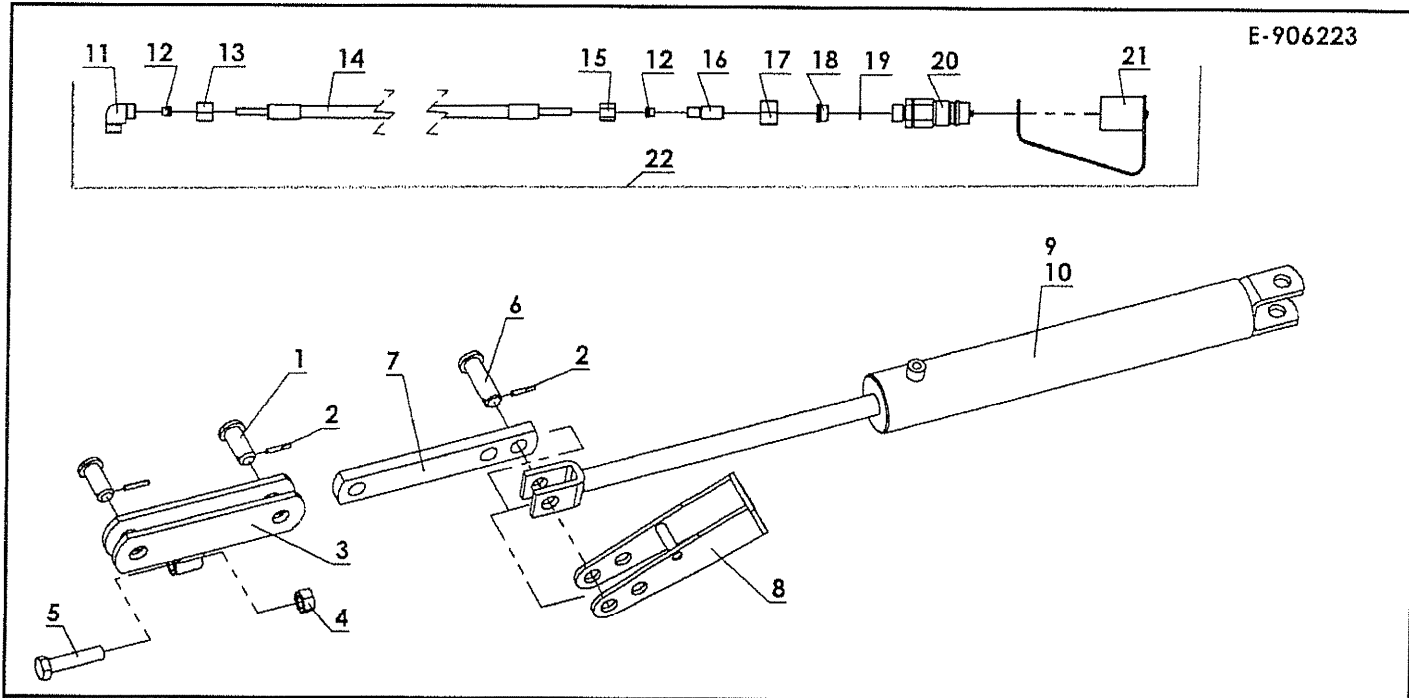

Pos Id-Nr. Stk. Beschreibung Description Désignation Benaming

2275

Zugstange mit Hydraulik

1	051865	2	Bolzen	Pin	Axe	Pen	
2	530042	3	Spannhülse	Tension pin	Goupille élastique	Spannhuls	5x30 DIN 1481 vz
3	051882	1	Hebel	Lever	Levier	Hendel	
4	510236	1	Sechskantmutter	Hex. nut	Ecrou	Moer, zeskant	M 16 DIN 934 vz 8
5	500890	1	Sechskantschraube	Hex. bolt	Vis	Bout, zeskant	M 16x70 DIN 933 vz
6	051823	1	Bolzen	Pin	Axe	Pen	
7	051881	1	Lasche	Tongue	Eclisse	Strip	
8	051822	1	Klappe	Linch	Attache	Borg	
9	051883	1	Zylinder	Cylinder	Vérin	Cilinder	
10	581086	1	Dichtungssatz	Set of seals	Jeu de Joints	Dichtingsset	
11	581065	1	Verschraubung	Screw fixing	Raccord	Nippel	WE 6-PSMK
12	581067	2	Ring	Ring	Joint torique	Ring	D6
13	581066	1	Mutter	Nut	Ecrou	Moer	M14x1,5 vz
14	581070	1	Hydraulikschlauch	Hydr. tube	Conduite flexible	Hydrauliekslang	1SN 6-1800-RSL6L-RSL6L
15	580788	1	Überwurfmutter	Swivel nut	Ecrou raccord	Moer, wartel	M 12 x 1,5
16	581071	1	Verschraubung	Screw fixing	Raccord	Nippel	
17	580429	1	Überwurfmutter	Swivel nut	Ecrou raccord	Moer, wartel	M 12 x1,5
18	580436	1	Schneidring	Cutting ring	Bague raccord	Snijring	12 L-S
19	016748	1	Drosselscheibe	Restrictor	Restricteur	Drosselschijf	1,2
20	580018	1	Kupplungsstecker	Connector	Accouplement rapide	Snelkoppeling	AG M 18x1,5
21	580060	1	Staubkappe	Dust cap	Cache-Poussière	Stofkap	
22	581072	1	Hydraulikbausatz	Hydraulik kit	Kit hydraulique	Hydrauliek set	

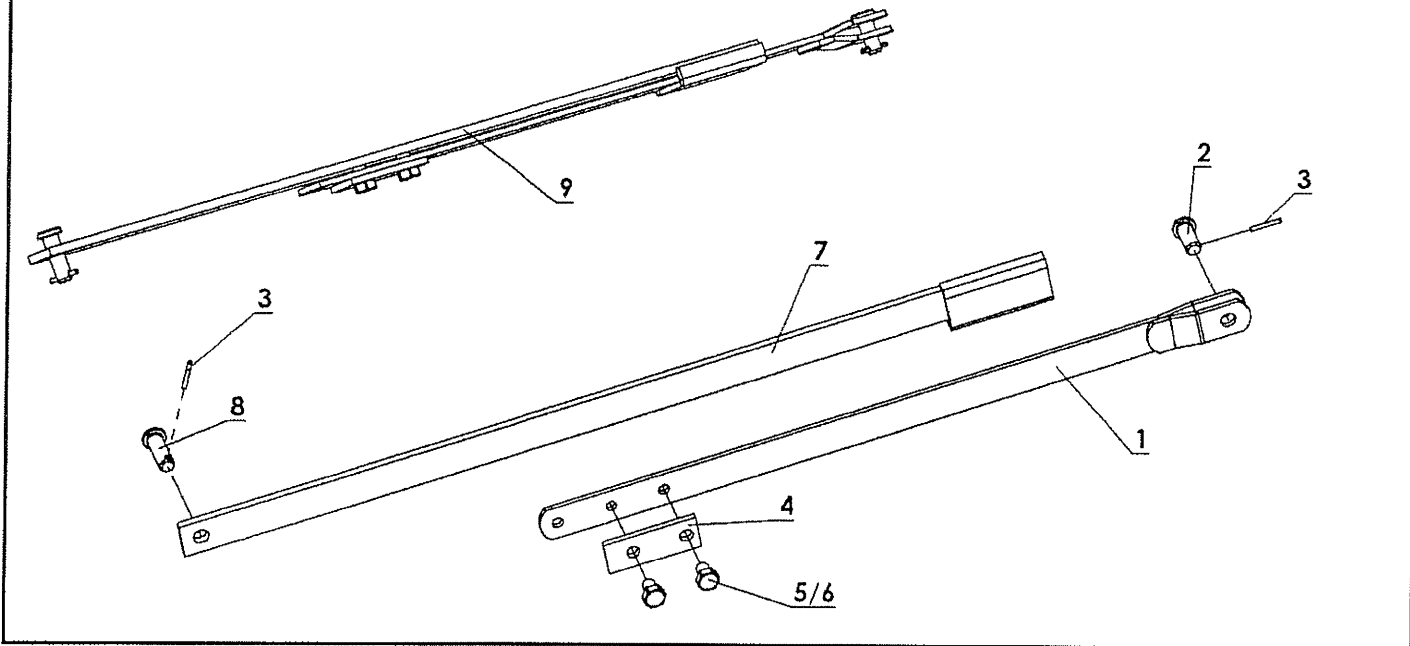

Pos	Id-Nr.	Stk.	Beschreibung	Description	Désignation	Benaming
-----	--------	------	--------------	-------------	-------------	----------

2284

Gestänge

1	025077	1	Zugstange	Tow bar	Bras de traction	Trekstang	
2	004420	1	Bolzen	Pin	Axe	Pen	
3	020400	2	Spannstift	Tension pin	Goupille élastique	Spanstift	4x30 DIN1481 vz
4	025082	1	Lasche	Tongue	Eclisse	Strip	
5	002111	2	Sechskantschraube	Hex. bolt	Vis	Bout, zeskant	M12x16 DIN933 vz
6	520502	2	Federring	Spring lock washer	Rondelle-frein	Veerring	B 12
7	025072	1	Zugstange	Tow bar	Bras de traction	Trekstang	
8	013727	1	Bolzen	Pin	Axe	Pen	
9	025071	1	Verstellstück	Adj. piece	Plaque de serage	Regelstuk	

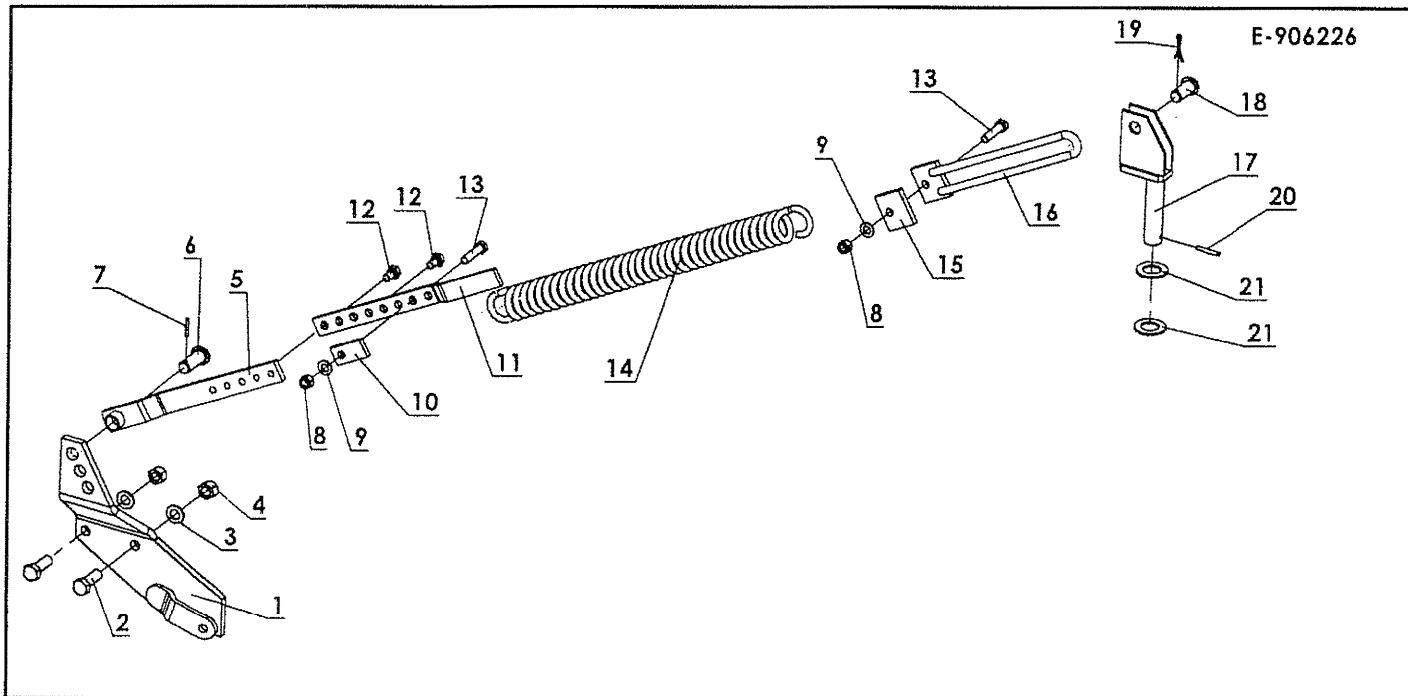

E-906226

2282

Federentlastung

Pos	Id-Nr.	Stk.	Beschreibung	Description	Désignation	Benaming	
1	051846	1	Flanschplatte	Flange	Bride	Steun	
2	500836	2	Sechskantschraube	Hex. bolt	Vis	Bout, zeskant	M 16x45 DIN 933 8.8 vz
3	520126	2	Scheibe	Washer	Rondelle	Schijf	17/30x3 DIN125 VZ
4	510452	2	Sechskantmutter	Hex. nut	Ecrou	Moer, zeskant	M 16 DIN 980 8
5	051905	1	Hebel	Lever	Levier	Hendel	
6	051909	1	Bolzen	Pin	Axe	Pen	
7	530042	1	Spannhülse	Tension pin	Goupille élastique	Spanhuls	5x30 DIN 1481 vz
8	510517	4	Sechskantmutter	Hex. nut	Ecrou	Moer, zeskant	M12 DIN 985 8 vz
9	520083	4	Scheibe	Washer	Rondelle	Schijf	13/24x2,5 DIN 125 vz
10	051906	1	Platte	Plate	Plaque	Plaat	
11	051904	1	Zuglasche				
12	500779	2	Sechskantschraube	Hex. bolt	Vis	Bout, zeskant	M 12x20 DIN 933 8.8
13	500501	1	Sechskantschraube	Hex. bolt	Vis	Bout, zeskant	M 12x50 DIN931 8.8 VZ
14	560116	1	Zugfeder	Tension spring	Ressort	Trekveer	
15	051902	1	Platte	Plate	Plaque	Plaat	
16	051903	1	Bügel	Stay	Etrier	Beugel	
17	051908	1	Konsole	Console	Console	Konsool	
18	051854	1	Bolzen	Pin	Axe	Pen	
19	530339	1	Splint	Split pin	Goupille fendue	Splitpen	5x30 DIN 94
20	530063	1	Spannhülse	Tension pin	Goupille élastique	Spanhuls	6x40 DIN1481 vz
21	520203	2	Scheibe	Washer	Rondelle	Schijf	29/50x3

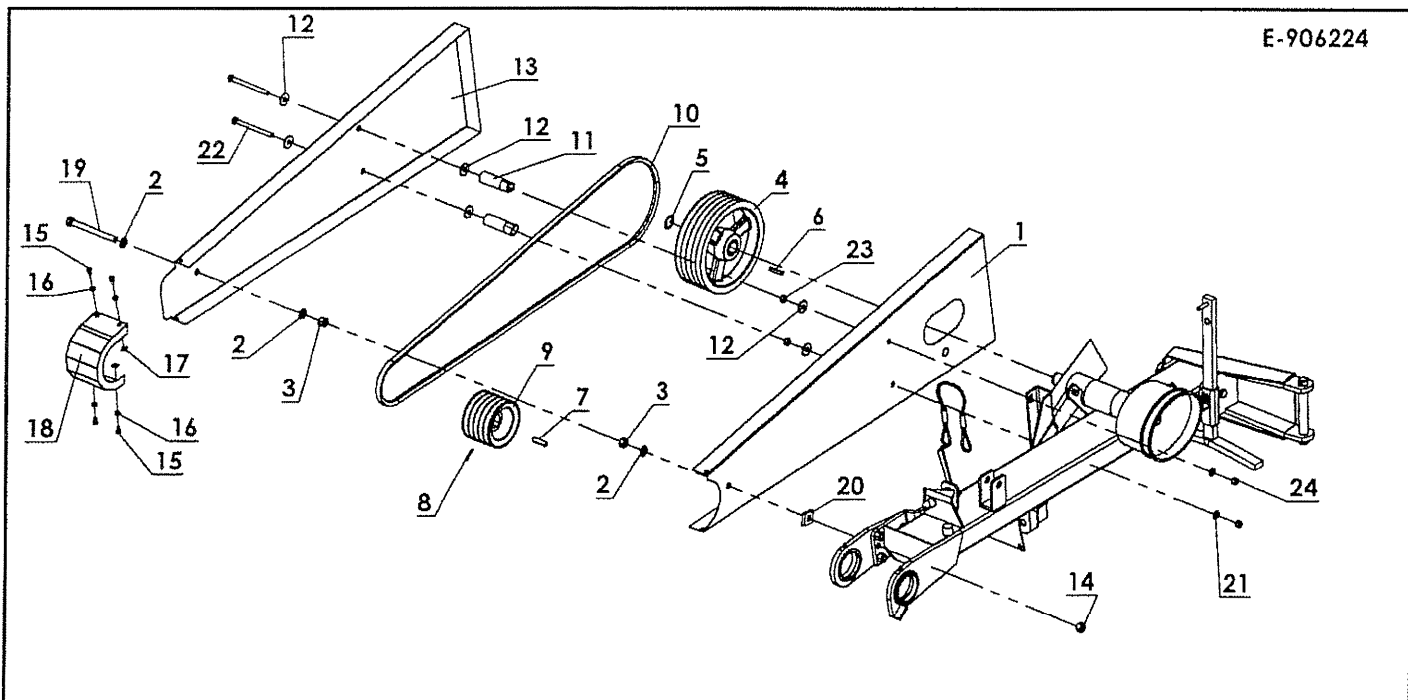

Pos Id-Nr. Stk. Beschreibung Description Désignation Benaming

2283

Antrieb 540 U/min

Pos	Id-Nr.	Stk.	Beschreibung	Description	Désignation	Benaming	
1	051818	1	Schutzkasten	Guard casing	Capot de protection	Beschermkast	
2	520105	4	Scheibe	Washer	Rondelle	Schijf	16,5/45x3
3	510309	1	Sechskantmutter	Hex. nut	Ecrou	Moer, zeskant	M 16 DIN 936 vz
4	051845	1	Keilriemenscheibe	V-belt pulley	Poulie à gorges	V-snaarschijf	
5	531524	2	Sicherungsring	Securing ring	Jonc d'arret	Borgring	A35x1,5 DIN472
6	531411	1	Paßfeder	Key	Clavette	Inlegspie	A 10x8x50 DIN6885 C45
7	531371	1	Paßfeder	Key	Clavette	Inlegspie	A12x8x50 DIN6885 C45
8	530208	1	Spannhülse	Tension pin	Goupille élastique	Spannhuls	6x35 vz DIN1481
9	051866	1	Keilriemenscheibe	V-belt pulley	Poulie à gorges	V-snaarschijf	
10	593876	5	Keilriemen	Belt	Courroie	V-snaar	
11	051859	2	Distanzrohr	Spacer	Entretoise	Afstandsbus	
12	520087	6	Scheibe	Washer	Rondelle	Schijf	13/37x3, DIN9021, vz
13	051817	1	Schutzdeckel	Cover	Garant-Couvercle	Deksel	
14	510452	1	Sechskantmutter	Hex. nut	Ecrou	Moer, zeskant	M 16 DIN 980 8
15	500756	4	Sechskantschraube	Hex. bolt	Vis	Bout, zeskant	M 8x12 DIN 933 8.8
16	520034	4	Scheibe	Washer	Rondelle	Schijf	8,4/17x1,6 DIN 125 A13
17	510772	4	Scheibe	Washer	Rondelle	Schijf	
18	051997	1	Schutzkasten	Guard casing	Capot de protection	Beschermkast	
19	500600	1	Sechskantschraube	Hex. bolt	Vis	Bout, zeskant	M 16x170 DIN933 vz
20	051861	1	Distanzstück	Spacer	Entretoise	Verhogingsstuk	
21	520083	2	Scheibe	Washer	Rondelle	Schijf	13/24x2,5 DIN 125 vz
22	019755	2	Sechskantschraube	Hex. bolt	Vis	Bout, zeskant	M 12x140 DIN933 vz
23	510229	4	Sechskantmutter	Hex. nut	Ecrou	Moer, zeskant	M12 DIN934 8 vz
24	510451	2	Sechskantmutter	Hex. nut	Ecrou	Moer, zeskant	M 12 DIN 980 8 vz

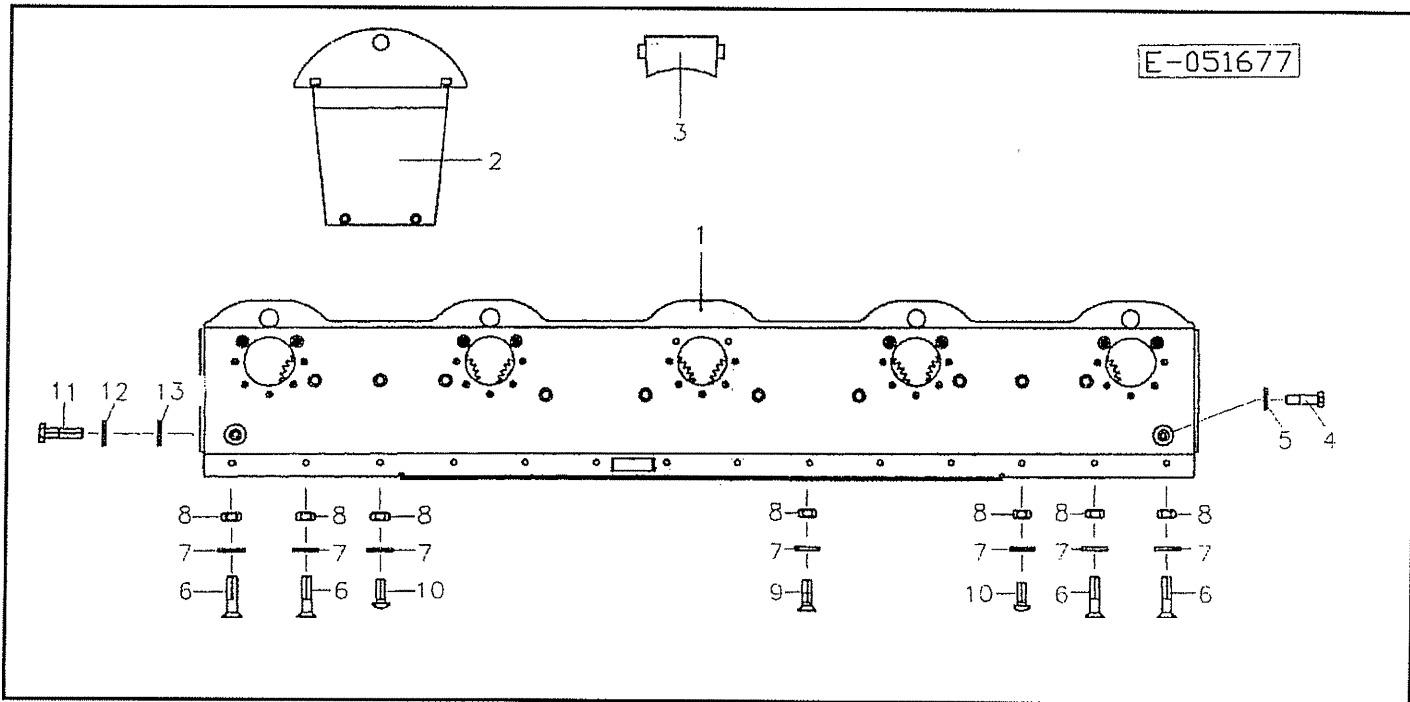

Pos Id-Nr. Stk. Beschreibung Description Désignation Benaming

2276

Getriebebalken

Pos	Id-Nr.	Stk.	Beschreibung	Description	Désignation	Benaming	
1	051677	1	Getriebebalken	cutter bar	système d'entraînement lamier	Aandrijfbalk	
2	050958	5	Gleitschuh	Shoe skid	Patin	Glijzool	
3	051289	4	Kloben	Chock	Gond	Blok	
4	501752	2	Zylinderschraube	Cylindrical bolt	Vis cylindrique	Bout, inbus	M12x16 DIN 6912 8.8 vz
5	551114	4	Kupferdichtung	Coupling	Accouplement	Koper afdichting	12/20x1,5
6	502442	10	Senkschraube	Countersunk bolt	Vis fraisée	Bout, verzonken	M 10x40 DIN7991vz
7	520049	14	Scheibe	Washer	Rondelle	Schijf	10,5/21x2 DIN 125 vz
8	510512	14	Sechskantmutter	Hex. nut	Ecrou	Moer, zeskant	M10 DIN985 8.8 vz
9	502437	4	Senkschraube	Countersunk bolt	Vis fraisée	Bout, verzonken	M 10x25 DIN7991vz
10	502672	2	Flachrundschrabe	Panhead bolt	Vis	Bolschroef	M10x35 vz DIN603
11	500942	3	Sechskantschraube	Hex. bolt	Vis	Bout, zeskant	M12x65, 10.9 vz.
12	520596	3	Sicherungsring	Securing ring	Jonc d'arret	Borgring	M 12
13	520083	3	Scheibe	Washer	Rondelle	Schijf	13/24x2,5 DIN 125 vz

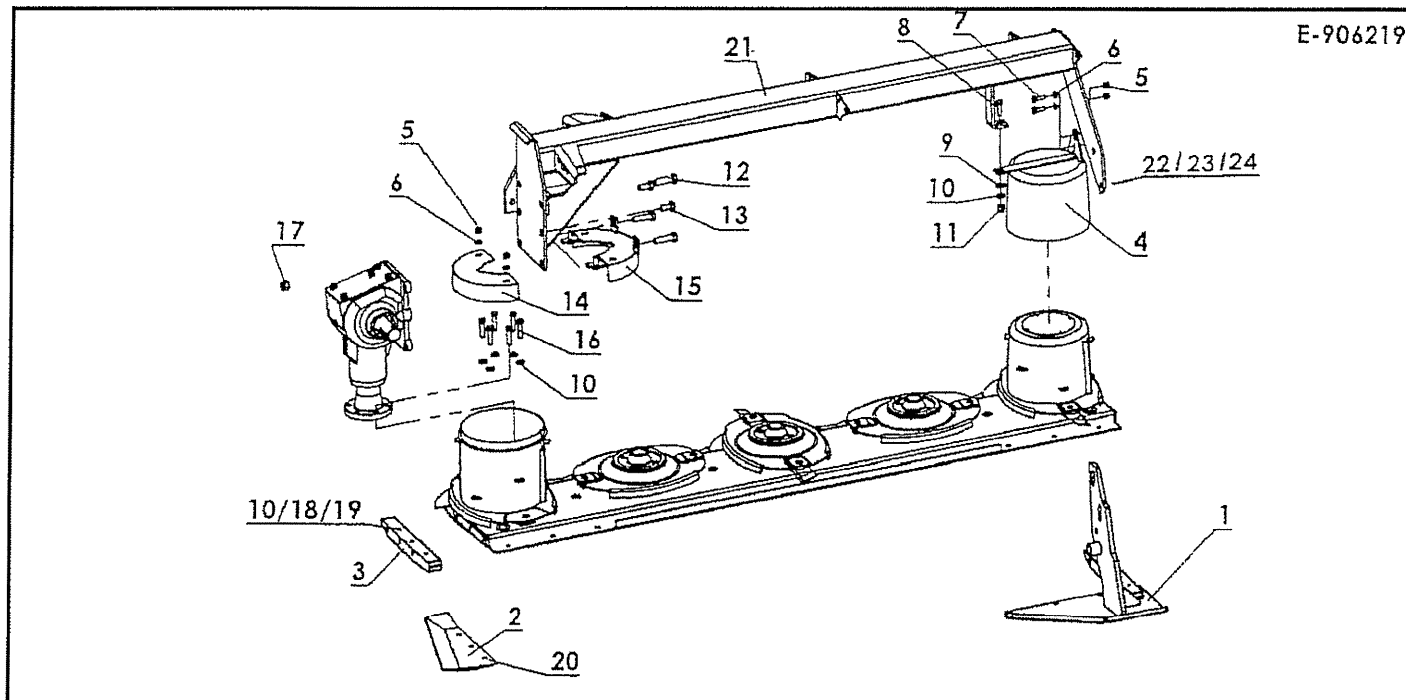

Pos	Id-Nr.	Stk.	Beschreibung	Description	Désignation	Benaming
-----	--------	------	--------------	-------------	-------------	----------

2285

Anbauteile

1	051653	1	Stütze	Support	Support	Steun	
2	051272	1	Gleitstück	Sliding piece	Support d'axe	Glijstuk	
3	052185	1	Halteplatte	Top bracket plate	Palier supérieur	Houder	
4	051475	1	Schutztopf	Protective lid	Protecteur	Beschermkap	
5	510512	6	Sechskantmutter	Hex. nut	Ecrou	Moer, zeskant	M10 DIN985 8.8 vz
6	520049	6	Scheibe	Washer	Rondelle	Schijf	10,5/21x2 DIN 125 vz
7	500772	2	Sechskantschraube	Hex. bolt	Vis	Bout, zeskant	M10x30 DIN 933 8.8 vz
8	500788	1	Sechskantschraube	Hex. bolt	Vis	Bout, zeskant	M 12x35 DIN 933 8.8 vz
9	520088	1	Scheibe	Washer	Rondelle	Schijf	13x28x3 vz
10	520596	6	Sicherungsring	Securing ring	Jonc d'arret	Borgring	M 12
11	510517	1	Sechskantmutter	Hex. nut	Ecrou	Moer, zeskant	M12 DIN 985 8 vz
12	501251	4	Sechskantschraube	Hex. bolt	Vis	Bout, zeskant	M16x1,5x55 vz
13	501260	2	Sechskantschraube	Hex. bolt	Vis	Bout, zeskant	M 16x1,5x35 DIN961
14	051664	1	Abdeckung	Safety cover	Protection	Afscherming	
15	051665	1	Abdeckung	Safety cover	Protection	Afscherming	
16	500910	6	Sechskantschraube	Hex. bolt	Vis	Bout, zeskant	M12x45 DIN933
17	510459	4	Sechskantmutter	Hex. nut	Ecrou	Moer, zeskant	M16x1,5 DIN 980
18	500942	3	Sechskantschraube	Hex. bolt	Vis	Bout, zeskant	M12x65, 10.9 vz.
19	520083	3	Scheibe	Washer	Rondelle	Schijf	13/24x2,5 DIN 125 vz
20	502442	3	Senkschraube	Countersunk bolt	Vis fraisée	Bout, verzonken	M 10x40 DIN7991vz
21	051876	1	Tragarm	Bearing arm	Support de tole	Draagarm	
22	500884	2	Sechskantschraube	Hex. bolt	Vis	Bout, zeskant	M16x50 DIN933 8.8 vz
23	018261	2	Scheibe	Washer	Rondelle	Schijf	17/40x6 vz.
24	510512	2	Sechskantmutter	Hex. nut	Ecrou	Moer, zeskant	M10 DIN985 8.8 vz

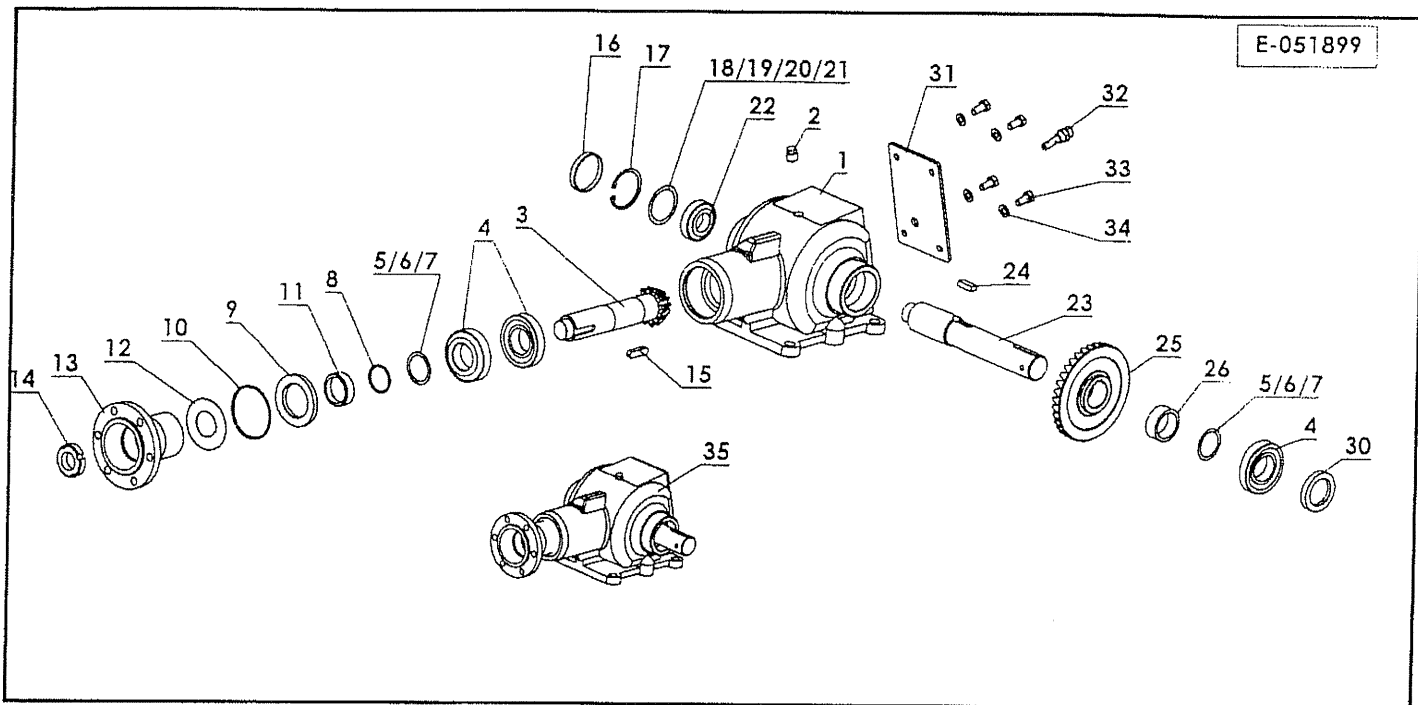

Pos	Id-Nr.	Stk.	Beschreibung	Description	Désignation	Benaming
-----	--------	------	--------------	-------------	-------------	----------

2280

Winkelgetriebe

Pos	Id-Nr.	Stk.	Beschreibung	Description	Désignation	Benaming	
1	051897	1	Gehäuse	Housing	Carter	Huis	
2	051895	1	Stopfen	Plug	Bouchon	Dop	
3	051888	1	Ritzelwelle	Splint shaft	Pignon d'attaque	Rondsel	
4	541058	3	Kegelrollenlager 30208	Taper roller bearing 30208	Roulement a galets 30208	Kegelrollenlager 30208	
5	520345	4	Paßscheibe	Adaptor washer	Rondelle de calage	Vulschijf	PS 40x50x0,1 DIN988
6	520346	4	Paßscheibe	Adaptor washer	Rondelle de calage	Vulschijf	PS 40x50x0,3 DIN988
7	520347	3	Paßscheibe	Adaptor washer	Rondelle de calage	Vulschijf	40/50x0,5 DIN988
8	550666	1	O-Ring	O-Ring	Joint torique	O-Ring	38x3
9	051890	1	Buchse	Bushing	Bague	Bus	
10	550084	1	Simmerring	Oil seal	Joint d'étanchéité	Keerring	BA 50/80x8
11	531861	1	Bund	Abutment shoulder	Bouchon	Bundel	
12	051891	1	Scheibe	Washer	Rondelle	Schijf	
13	051643	1	Flansch	Flange	Flasque	Flens	
14	510739	1	Nutmutter	Grooved nut	Ecrou	Moer, borg	M30x1,5 DIN1804
15	531352	1	Paßfeder	Key	Clavette	Inlegspie	A 10x8x40 DIN 6885
16	551502	1	Verschlußdeckel	Locking cover	Porte d'accès	Sluitdop	
17	531640	1	Sicherungsring	Securing ring	Jonc d'arrêt	Borgring	J 62x2 DIN 472
18	520356	1	Paßscheibe	Adaptor washer	Rondelle de calage	Vulschijf	50/62x0,1
19	520357	1	Paßscheibe	Adaptor washer	Rondelle de calage	Vulschijf	50/62x0,2
20	520368	1	Paßscheibe	Adaptor washer	Rondelle de calage	Vulschijf	72x85x0,35 DIN 988
21	520359	1	Paßscheibe	Adaptor washer	Rondelle de calage	Vulschijf	50/62x0,5
22	541059	1	Kegelrollenlager 30206	Taper roller bearing	Roulement a galets	Kegelrollenlager 30206	
23	051892	1	Welle	Shaft	Arbre	As	
24	531434	1	Paßfeder	Key	Clavette	Inlegspie	8x7x50
25	051893	1	Kegelrad	Pinion	Pignon conique	Kegeltandwiel	
26	051894	1	Scheibe	Washer	Rondelle	Schijf	
27	520345	4	Paßscheibe	Adaptor washer	Rondelle de calage	Vulschijf	PS 40x50x0,1 DIN988
28	520346	4	Paßscheibe	Adaptor washer	Rondelle de calage	Vulschijf	PS 40x50x0,3 DIN988
29	520347	3	Paßscheibe	Adaptor washer	Rondelle de calage	Vulschijf	40/50x0,5 DIN988
30	550139	1	Dichtring	Sealing ring	Joint	Afdichting	593039
31	051896	1	Deckel	Cover	Couvercle	Deksel	
32	570343	1	Entlüftungsventil	Breather	Reniflard	Ontluchttingsventiel	503028
33	500874	4	Sechskantschraube	Hex. bolt	Vis	Bout, zeskant	M10x20 DIN 933 8.8vz
34	520577	4	Sicherungsring	Securing ring	Jonc d'arrêt	Borgring	VS 10
35	051899	1	Antrieb	Drive	Chemise	Aandrijving	

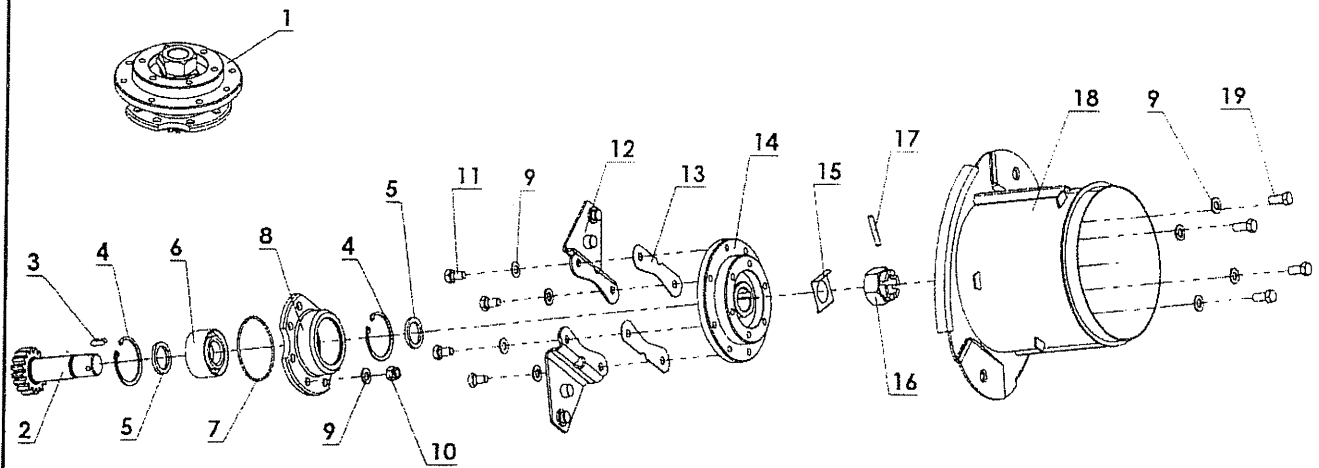

Pos	Id-Nr.	Stk.	Beschreibung	Description	Désignation	Benaming
-----	--------	------	--------------	-------------	-------------	----------

2278

Trommelantrieb

1	051678	1	Antrieb	Drive	Chemise	Aandrijving	
2	051645	1	Ritzelwelle	Splint shaft	Pignon d'attaque	Rondsel	
3	531425	1	Paßfeder	Key	Clavette	Inlegspie	A8x8x25 DIN6885 vg
4	531647	2	Sicherungsring	Securing ring	Jonc d'arrêt	Borgring	J 72x2,5 DIN 472
5	051207	2	Ring	Ring	Joint torique	Ring	
6	540911	1	Kugellager	Ball bearing	Roulement a bille	Kogellager	2-Reihig 3306
7	550584	1	O-Ring	O-Ring	Joint torique	O-Ring	OR 90x3
8	050865	1	Flanschlager	Flange bearing	Palier	Flenslager	
9	520596	15	Sicherungsring	Securing ring	Jonc d'arrêt	Borgring	M 12
10	510517	7	Sechskantmutter	Hex. nut	Ecrou	Moer, zeskant	M12 DIN 985 8 vz
11	500779	4	Sechskantschraube	Hex. bolt	Vis	Bout, zeskant	M 12x20 DIN 933 8.8
12	570440	2	Messerhalter	Blade holder	Support de couteau	Meshouder	
13	050653	2	Sicherungsblech	Locking plate	Plaque-frein	Borgplaat	
14	051644	1	Flansch	Flange	Flasque	Flens	
15	050867	1	Sicherung	Safety bracket	Sécurité	Veiligheid	
16	510647	1	Kronenmutter	Crown nut	Ecrou a couronne	Kroonmoer	M33x2 DIN935
17	530081	1	Spannhülse	Tension pin	Goupille élastique	Spanhuis	7x50 DIN 1481
18	050374	1	Mähtrommel	Drum	Tombeur de tondeuse	Maaitrommel	
19	500926	4	Sechskantschraube	Hex. bolt	Vis	Bout, zeskant	M12x25 DIN933 vz

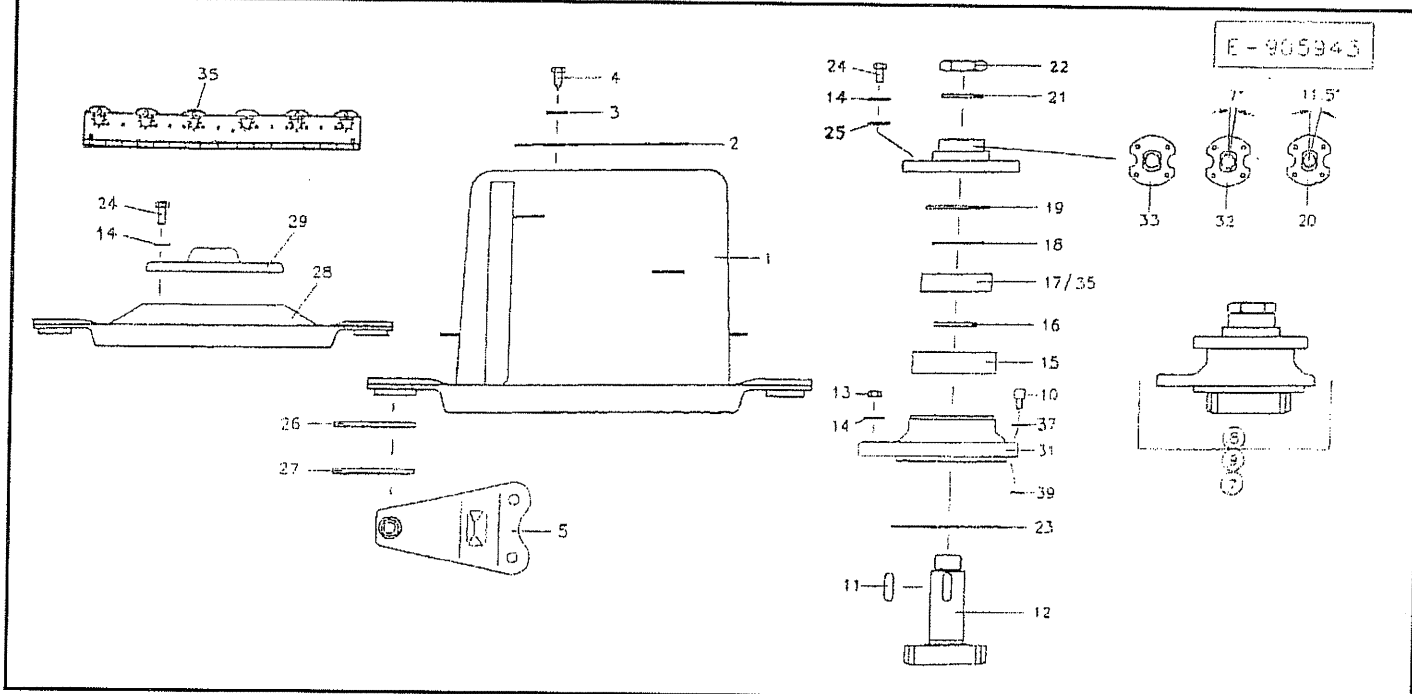

2279

Mähscheibe

Pos	Id-Nr.	Stk.	Beschreibung	Description	Désignation	Benaming	
1	050369	1	Mähtrommel	Drum	Tombeur de tondeuse	Maaitrommel	
2	050250	1	Deckel	Cover	Couvercle	Deksel	
3	520019	4	Scheibe	Washer	Rondelle	Schijf	
4	503080	4	Blechschaube	Sheet metal screw	Vis	Plaatschroef	6,4/18x1,6 DIN 9021 vz B 6,3x16 DIN 7976
5	570441	8	Messerhalter	Blade holder	Support de couteau	Meshouder	
7	050807	1	Antrieb für Mähtrommel	Drive for Drum	chemise pour tambeur	Andrijving voor Maaitrommel	
8	018070	2	Antrieb	Drive	Chemise	Aandrijving	
9	018072	1	Antrieb	Drive	Chemise	Aandrijving	
10	570333	1	Entlüftungsfilter	Air-Valve-Filter	Reniflard	Ontluchtingsfilter	
11	531398	4	Paßfeder	Key	Clavette	Inlegspie	1080-81-00
12	017272	4	Welle	Shaft	Arbre	As	B8x8x18 DIN6885 vg
13	510517	28	Sechskantmutter	Hex. nut	Ecrou	Moer, zeskant	M12 DIN 985 8 vz
14	520596	44	Sicherungsring	Securing ring	Jonc d'arret	Borgring	M 12
15	540254	4	Rillenkugellager	Grooved ball bearing	Roulement	Kogellager	6306 2RS C3
16	014988	4	Ring	Ring	Joint torique	Ring	
17	540156	3	Rillenkugellager	Grooved ball bearing	Roulement	Kogellager	6206 2RS C3
18	520333	4	Paßscheibe	Adaptor washer	Rondelle de calage	Vulschijf	PS 30x42x1
19	550355	4	Nilos-Ring	Nilos-Ring	Rondelle d'étanchéité	Nilosring	6206 AV
20	017435	1	Flansch	Flange	Flasque	Flens	11,5°
21	017110	4	Sicherungsscheibe	Washer	Rondelle de sécurité	Borgschijf	
22	510367	4	Sechskantmutter	Hex. nut	Ecrou	Moer, zeskant	M 24x1,5 DIN 936 8
23	550584	4	O-Ring	O-Ring	Joint torique	O-Ring	OR 90x3
24	500926	16	Sechskantschraube	Hex. bolt	Vis	Bout, zeskant	M12x25 DIN933 vz
25	520083	16	Scheibe	Washer	Rondelle	Schijf	13/24x2,5 DIN 125 vz
26	570679	4	Messer Klinge	Cutter blade	Couteau	Mes	107x48x4
27	570680	6	Messer Klinge	Cutter blade	Couteau	Mes	107x48x4
28	050359	3	Mähscheibe	Disc	Disque	Maaischijf	
29	014991	3	Deckel	Cover	Couvercle	Deksel	
31	017888	4	Lagerflansch	Bearing flange	Palier	Lagerflens	X17302
32	050608	2	Flansch	Flange	Flasque	Flens	7°
33	017287	1	Flansch	Flange	Flasque	Flens	0°
35	540158	1	Rillenkugellager	Grooved ball bearing	Roulement	Kogellager	T.206 KXN 4
37	551100	1	Kupferdichtung	Coupling	Accouplement	Koper afdichting	8x12x1,5
39	550502	1	O-Ring	O-Ring	Joint torique	O-Ring	OR 10x2

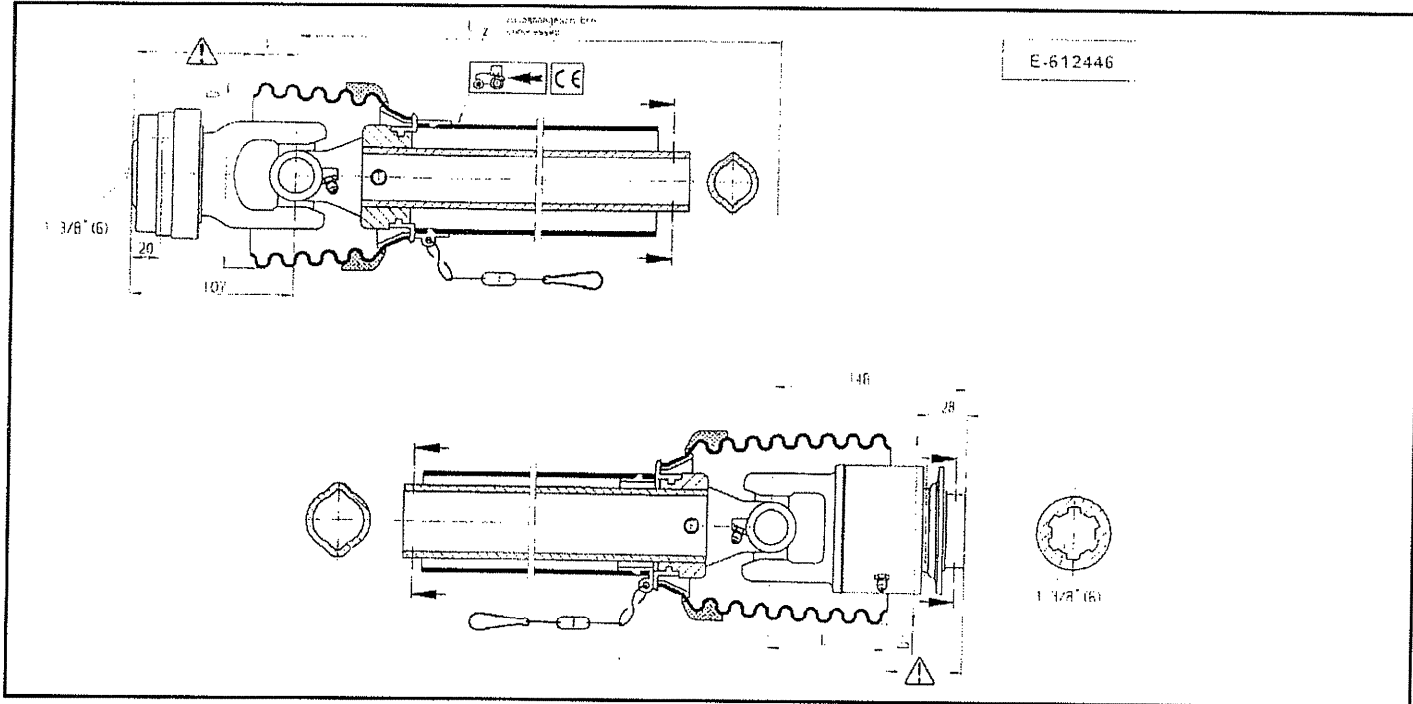

Pos	Id-Nr.	Stk.	Beschreibung	Description	Désignation	Benaming
-----	--------	------	--------------	-------------	-------------	----------

2277

Gelenkwelle 612446 (690405)

1	612446	1	Gelenkwelle 612446 (690405)			
---	--------	---	--------------------------------	--	--	--

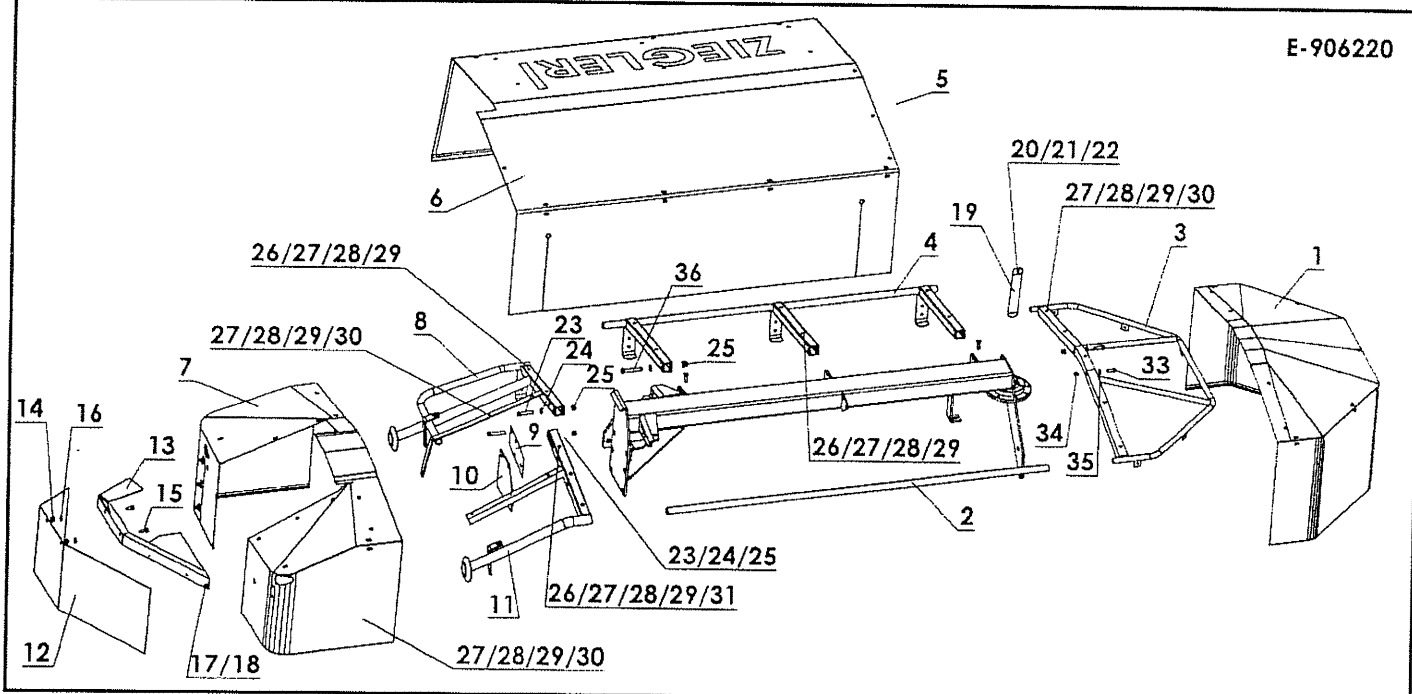

Pos	Id-Nr.	Stk.	Beschreibung	Description	Désignation	Benaming
-----	--------	------	--------------	-------------	-------------	----------

2281

Schutz

1	600989	1	Schutztuch	Skirt	Toile	Beschermdoek	
2	051878	1	Rohr	Pipe	Tuyau	Buis	
3	051661	1	Schutzrahmen	Safety frame	Etrier	Beschermbeugel	
4	051877	1	Schutzrahmen	Safety frame	Etrier	Beschermbeugel	
5	600397	12	Riemen	Belt	Courroie	Snaar	150
6	600997	1	Schutztuch	Skirt	Toile	Beschermdoek	
7	600991	1	Schutztuch	Skirt	Toile	Beschermdoek	
8	051606	1	Schutzrahmen	Safety frame	Etrier	Beschermbeugel	
9	051872	1	Schutzblech	Safety cover	Toile de protection	Beschermplaat	
10	051873	1	Platte	Plate	Plaque	Plaat	
11	051868	1	Schutzrahmen	Safety frame	Etrier	Beschermbeugel	
12	600995	1	Schutztuch	Skirt	Toile	Beschermdoek	
13	051870	1	Halter	Bracket	Support	Houder	
14	520049	2	Scheibe	Washer	Rondelle	Schijf	10,5/21x2 DIN 125 vz
15	500771	2	Sechskantschraube	Hex. bolt	Vis	Bout, zeskant	M 10x25 DIN 933 vz
16	510512	2	Sechskantmutter	Hex. nut	Ecrou	Moer, zeskant	M10 DIN985 8.8 vz
17	503080	5	Blechschaube	Sheet metal screw	Vis	Plaatschroef	B 6,3x16 DIN 7976
18	520018	5	Scheibe	Washer	Rondelle	Schijf	6,4/12,5x1,6 DIN 125
19	560619	10	Blattfeder	Leaf spring	Stabilisateur	Bladveer	
20	500733	10	Sechskantschraube	Hex. bolt	Vis	Bout, zeskant	M 6x20 DIN 933 8.8
21	520019	20	Scheibe	Washer	Rondelle	Schijf	6,4/18x1,6 DIN 9021 vz
22	510505	10	Sechskantmutter	Hex. nut	Ecrou	Moer, zeskant	M 12 x 40 DIN 933
23	500789	4	Sechskantschraube	Hex. bolt	Vis	Bout, zeskant	M6 DIN 985 8 vz
24	520083	10	Scheibe	Washer	Rondelle	Schijf	13/24x2,5 DIN 125 vz
25	510517	9	Sechskantmutter	Hex. nut	Ecrou	Moer, zeskant	M12 DIN 985 8 vz
26	500442	10	Sechskantschraube	Hex. bolt	Vis	Bout, zeskant	M8x55 DIN931 8.8
27	520035	25	Scheibe	Washer	Rondelle	Schijf	28x8,4x2 CADM
28	520034	25	Scheibe	Washer	Rondelle	Schijf	8,4/17x1,6 DIN 125
29	510509	25	Sechskantmutter	Hex. nut	Ecrou	Moer, zeskant	M 8 DIN 985 8 vz
30	500743	14	Sechskantschraube	Hex. bolt	Vis	Bout, zeskant	M8x20 DIN 933 8.8 vz
31	500375	1	Sechskantschraube	Hex. bolt	Vis	Bout, zeskant	M 8x65 DIN 931 8.8 vz
32	500783	2	Sechskantschraube	Hex. bolt	Vis	Bout, zeskant	M12x25 DIN933 8.8 vz
33	500772	4	Sechskantschraube	Hex. bolt	Vis	Bout, zeskant	M10 DIN985 8.8 vz
34	510512	4	Sechskantmutter	Hex. nut	Ecrou	Moer, zeskant	M10x30 DIN 933 8.8 vz
35	520049	2	Scheibe	Washer	Rondelle	Schijf	10,5/21x2 DIN 125 vz
36	500386	3	Sechskantschraube	Hex. bolt	Vis	Bout, zeskant	M12x75 DIN931 8.8 vz

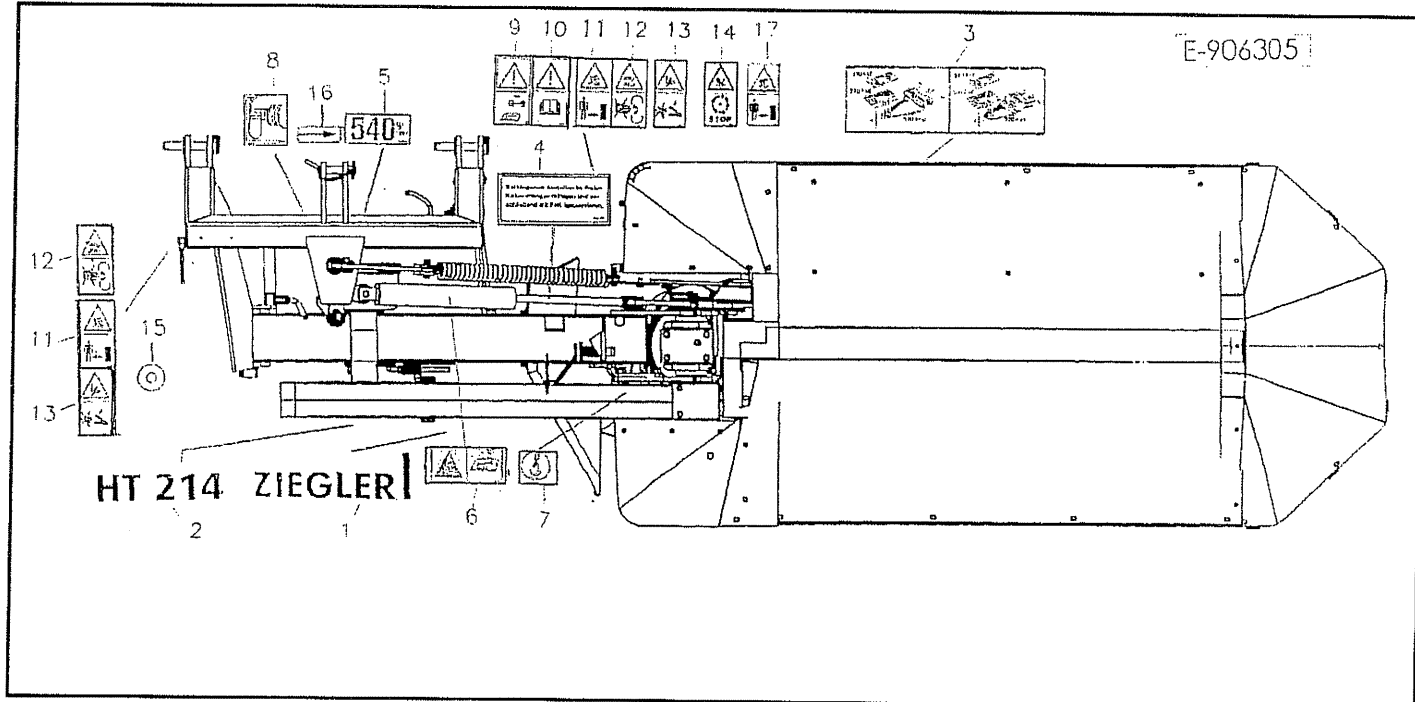

Pos	Id-Nr.	Stk.	Beschreibung	Description	Désignation	Benaming
-----	--------	------	--------------	-------------	-------------	----------

2286

Aufkleberliste

1	647045	1	Aufkleber	sticker	auto-collant	sticker
2	647046	1	Abziehbild	Decal	Décalque	Sticker
3	646986	1	Abziehbild	Decal	Décalque	Sticker
4	646984	1	Abziehbild	Decal	Décalque	Sticker
5	646358	1	Abziehbild	Decal	Décalque	Sticker
6	646837	1	Aufkleber	sticker	auto-collant	sticker
7	646246	1	Abziehbild	Decal	Décalque	Sticker
8	646882	1	Abziehbild	Decal	Décalque	Sticker
9	646413	2	Abziehbild	Decal	Décalque	Sticker
10	646407	1	Abziehbild	Decal	Décalque	Sticker
11	646405	2	Abziehbild	Decal	Décalque	Sticker
12	646417	2	Abziehbild	Decal	Décalque	Sticker
13	646415	2	Abziehbild	Decal	Décalque	Sticker
14	646411	2	Abziehbild	Decal	Décalque	Sticker
15	646985	1	Abziehbild	Decal	Décalque	Sticker
16	004700	1	Abziehbild	Decal	Décalque	Sticker
17	646408	2	Abziehbild	Decal	Décalque	Sticker



Member of the
Ziegler Group

www.ziegler-landtechnik.com

ZIEGLER |

Ziegler GmbH
Schrobenhausener Str. 74
D-86554 Pöttmes

T.: +49 (0) 8253/9997- 0
F.: +49 (0) 8253/9997-47
W.: www.ziegler-landtechnik.com
E.: vertrieb@ziegler-gmbh.com